

JOINT GIBAULT

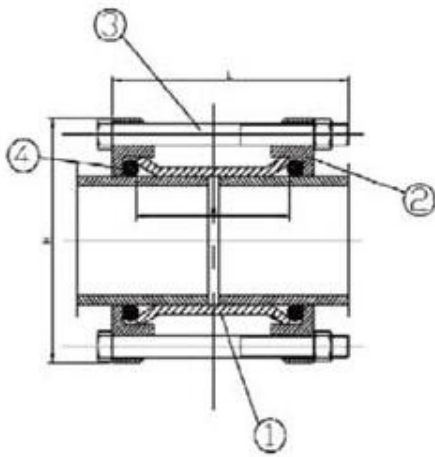

No.	Référence	Matériel
1	Manchette	Fonte GGG450-10
2	Contre bride	Fonte GGG450-10
3	Boulonnerie	Acier 8.8 Dacromet
4	Joint	EPDM/NBR

PN 10 / 16

-Revêtement époxy 250µm

Boulons			A	H	Poid
SIZE	L	QITY	MM	MM	KGS
DE63	M10 × 160	2	147	90	1.5
DE75	M10 × 160	2	149	90	1.7
DE90	M10 × 170	2	164	100	2.0
DE110	M10 × 180	3	184	100	2.8
DE125	M12 × 180	3	199	100	3.4
DE140	M12 × 200	3	214	116	3.9
DE160	M12 × 210	3	234	130	5.5
DE180	M12 × 220	3	254	140	7.0
DE200	M12 × 230	3	274	150	8.5
DE250	M14 × 250	3	341	155	12.5
DE315	M14 × 260	4	406	170	18.0
DE400	M14 × 280	6	495	180	20.0
DE500	M14 × 280	8	592	180	24.0